

EMI COMMON-MODE LINE FILTER/ECC SERIES

COMPONENT

PRODUCT IDENTIFICATION

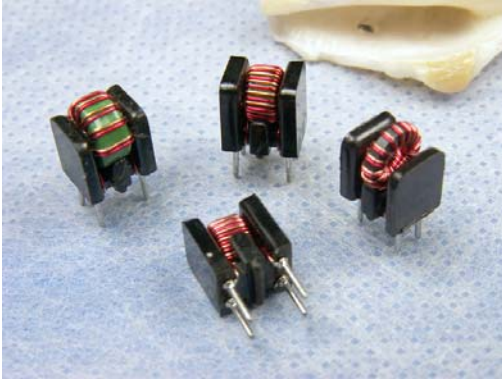

ECC 806470 - 800
A B C

A : EMI COMMON CHOKE
 B : DIMENSION
 C : INDUCTANCE

APPLICATIONS

Double balance mixers, broad-band transformers, impedance transformers, etc.

SHAPES & DIMENSIONS

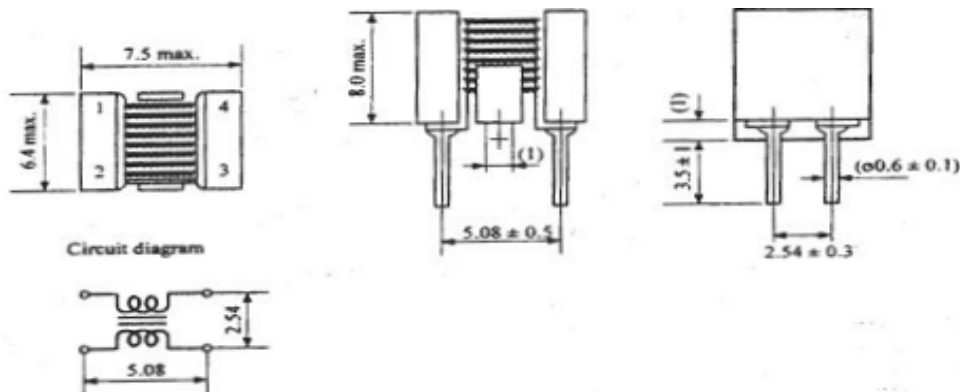

ELECTRICAL CHARACTERISTICS

MODEL	150	400	600	800	101	121
Rated Voltage (V)	50	50	50	50	50	50
Rated Current (mA) Max.	500	500	500	500	500	500
Inductance (uH)	15±50%	40±50%	60±35%	80±35%	100±35%	120±35%
DC Resistance (MΩ) Max.	35	45	50	60	70	80
Min. Insulation Resistance (MΩ)	10	10	10	10	10	10

MATERIALS :

- a. CORE : FERRITE TR CORE
- b. WIRE : ENAMELLED COPPER WIRE
- c. CASE : PHENOLIC